



ULTRATECNO
POWER ULTRASONIC CLEANING

ACM-650E

High Power Ultrasonic Cleaner for Heavy Duty applications



Pneumatic Platform lift

Insulated lid

ARF[®] noise reduction

Triple thermal insulation

Full Stainless Steel construction

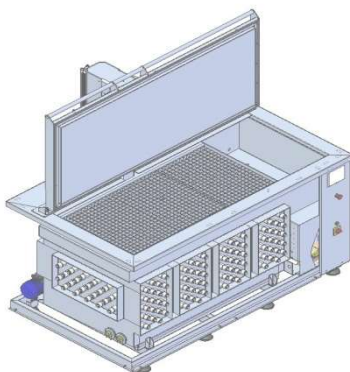

Protected Ceramic Heaters

LFS[®] Oil Separation

28 kHz Powerful Ultrasound

Replaceable transducers

Maximum Useful dimensions

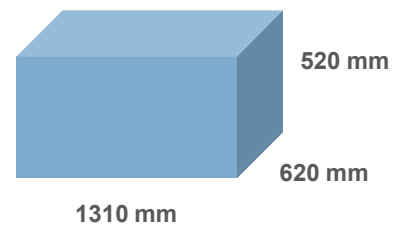

At least 100-150 mm of free space surrounding the parts is required to allow proper ultrasonic diffusion. Don't overload the tank, to get good cleaning performance.

The most powerful Ultrasonic equipment at market

UltraTecnno
Valencia, SPAIN
+34 961 666 565 - info@ultratecnno.es
www.ultratecnno.eu



Main tank internal dimensions 1370 x 800 x 800 mm (789 litres)
Full stainless steel construction AISI 304/316L - 2 mm thickness - Height adjustable legs
External Dimensions with Top Lid Open / Weight 2070 x 1300 x 1920 mm / 600 kg

Ultrasonic System Frequency 28 kHz
Ultrasonic Actual Power 5000 W (5 sets) Synchronized Generators
Sweep Frequency Digital \pm 2% for smooth & safe cleaning
Ultrasonic Emitters Sets 316L welded at walls (replaceable)
Noise Reduction System Patented ARF[©] <78db (A)

Elevator for agitation with platform lift Pneumatic, max load 500 kg

Oil Separation System Patented LFS[©] with Pump, Auxiliary tank
LFS[®] Recirculation pump Stainless Steel EBARA CDX

Heating System 11 kW Ceramic Heaters into protective stainless-steel housing
Acoustic & Thermal Insulation thickness Fire & Sound proof Stone rock 50 mm
Insulated Top Lid 30 mm thermal & acoustic insulation
Safety water Level Sensor Electronic IFM LMT-102 (SS316-PEEK)

Inset Multilanguage 7" Color HMI Touch screen Manual & Automatic Preset Cycles
Full process parameters customization
Heating & US Programmable Timer / Preventive Maintenance Schedule
Electrical Consumption Monitor / Detergent calculator / Hourly & starts counter

Optional Devices Available Filtering / Automatic Water Refill /
Hybrid Heating / Small parts basket /
Steam Extraction / Automatic Top Lid Opening / Hands Free Operation Pedal



28kHz
Synchronized



Durable
Construction



Green
Label



Low noise
Emission



Smart
Interface



Best cost effective
Cleaner