



ULTRATECNO
POWER ULTRASONIC CLEANING

ACM-300E

High Power Ultrasonic Cleaner for Heavy Duty applications



ARF[®]
Acoustic
Reduction Filter

LFS[®]
Laminar
Flow System

Pneumatic Platform lift

Insulated lid

ARF[®] noise reduction

Triple thermal insulation

Full Stainless Steel construction

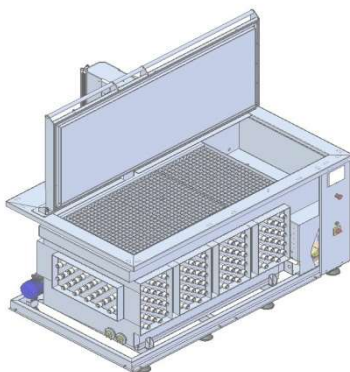

Stainless Steel Electric heater

LFS[®] Oil Separation

28 kHz Powerful Ultrasound

Replaceable transducers

Maximum Useful dimensions

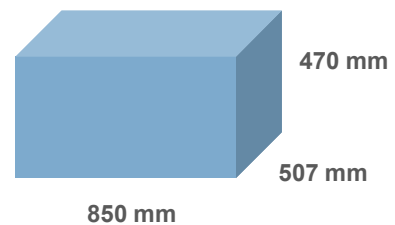

At least 100-150 mm of free space surrounding the parts is required to allow proper ultrasonic diffusion. Don't overload the tank, to get good cleaning performance.

The most powerful Ultrasonic equipment at market

UltraTecnno
Valencia, SPAIN
+34 961 666 565 - info@ultratecnno.es
www.ultratecnno.eu

Main tank internal dimensions	900 x 650 x 650 mm (380 litres)
Full stainless steel construction	AISI 304/316L - 2 mm thickness - Height adjustable legs
External Dimensions with Top Lid Open / Weight	1500 x 1030 x 1800 mm / 430 kg

Ultrasonic System Frequency	28 kHz
Ultrasonic Actual Power	3000 W (3 sets) Synchronized Generators
Sweep Frequency	Digital \pm 2% for smooth & safe cleaning
Ultrasonic Emitters Sets	316L welded at walls (replaceable)
Noise Reduction System	Patented ARF [©] <78db (A)

Elevator for agitation with platform lift	Pneumatic, max load 235 kg
---	----------------------------

Oil Separation System	Patented LFS [©] with Pump, Auxiliary tank
LFS [®] Recirculation pump	Stainless Steel EBARA MATRIX 3-2T

Heating System	7,5 kW stainless-steel heaters
Acoustic & Thermal Insulation thickness	Fire & Sound proof Stone rock 50 mm
Insulated Top Lid	30 mm thermal & acoustic insulation
Safety water Level Sensor	Electronic IFM LMT-102 (SS316-PEEK)

Inset Multilanguage 7" Color HMI Touch screen	Manual & Automatic Preset Cycles Full process parameters customization Heating & US Programmable Timer / Preventive Maintenance Schedule Electrical Consumption Monitor / Detergent calculator / Hourly & starts counter
---	---

Optional Devices Available	Filtering / Automatic Water Refill / Hybrid Heating / Small parts basket / Steam Extraction / Automatic Top Lid Opening / Hands Free Operation Pedal
----------------------------	--



28kHz
Synchronized



Durable
Construction



Green
Label



Low noise
Emission



Smart
Interface



Best cost effective
Cleaner